

NOW WITH 100%
CUSTOMER SATISFACTION
GUARANTEE

LAARS[®] MASCOT[®] II

Gas-Fired Wall-Mounted
Combination Boiler &
Hot Water Heater



LAARS[®] 
Heating Systems Company
A subsidiary of **BRADFORD WHITE[®]** Corporation

High Efficiency Mascot® II Boilers

The Mascot II is a 125 MBTU heating only or combination ("Combi" - heating and domestic hot water) wall mounted boiler packed with features and benefits that both the homeowner and contractor can enjoy.

For the homeowner, the Mascot II offers a 95% plus efficiency rating for lower operating costs, has "zero clearance installation" so it can fit just about anywhere and has a modern appliance design. It is a reliable, quiet, smooth operating boiler that has enough output to keep your home warm with continuous hot water for long relaxing showers.

Contractors will love the Mascot II because they install in less time than other units do, thanks to the service-friendly design and full package of system components. Components are easily accessible for disassembly, should an unlikely call for service be required, saving service time and money.

Boiler setup is a breeze because of full access to both the gas valve and control panel at the same time (see figure on following page). The gas valve is accessible directly behind the front lower panel that rotates down via a hinged connection. While the lower panel is open, the center console that houses the control display remains closed and fully visible.

- Sleek, appliance-grade cabinet that looks great in any location
- Up to 95%+ efficiency, condensing operation
- 2-year parts warranty, 10-year heat exchanger warranty
- Energy Star qualified
- Zero Installation Clearance
- Sealed combustion
- Direct spark ignition for smooth reliable starts
- Two venting options to meet the needs of almost any installation
- Optimized gas usage for lower energy bills via 20% to 100% input modulating gas valve
- Quiet variable speed blower
- Boilers are set up for natural gas, no parts necessary for conversion to LP gas
- Built in expansion tank that will handle 26 gallons of system water (enough to cover 1,800 feet of ½" PEX tubing)
- Three speed circulator with air vent and "quick-remove" mounting system
- Automatic 3-way valve for DHW priority eliminates the need for separate zone setup when using an indirect DHW tank
- Mounting kit with template and wall bracket for fast and easy installation
- Light-weight (100 lbs.) makes handling easy
- Stainless steel A.S.M.E. primary heat exchanger with externally welded manifolds for better flow rates and prevention of leaks
- Stainless steel brazed plate DHW heat exchanger (combi models) with advanced flow switch
- Hydronic system water pressure sensor for safety at low water levels
- Advanced Laars integrated control system with temperature control, diagnostics, outdoor reset capability, and easy access for field wiring
- Unique, sealed condensate trap does not need to be primed at startup
- Pump Freeze Protection

MASCOT® II

INTELLIGENTLY DESIGNED



Air elimination valve

Concentric or two-pipe venting connections, two-pipe connection uses standard off the shelf PVC or CPVC piping.

A built in expansion tank eliminates unsightly externally mounted tanks

Each Mascot II uses a state of the art, condensing, stainless steel heat exchanger with a 5:1 turndown. The design delivers 95% AFUE, a low 10ppm NOx emissions and only 1.5 amp electrical draw resulting in one of the most environmentally friendly, compact, combination units on the market.

System is fully protected with resettable circuit breakers

Each Mascot II is supplied with a unique, sealed condensate trap that does not need priming at startup.

Every Mascot II is equipped with an advanced Laars integrated LCD push button control system, illuminated power switch and pressure gauge. Temperature control, diagnostics, outdoor reset capability and many other functions are seamlessly integrated in this one easy to use center console.

Laars advanced integrated control system

The Mascot II lower door opens independently from the rest of the unit allowing access to both the gas valve and controls at the same time, making setup very easy.



Mascot II boilers are designed with a built-in expansion tank, air elimination vent, three-speed circulator, primeless condensate trap and direct access to wiring. These features, along with a wall-mounting template, save contractors hundreds of dollars in material & labor and help reduce installation errors. Not to mention most components are “off the shelf” replacement parts and can easily be obtained from many distribution locations.

LAARS® MASCOT® II DIMENSIONS

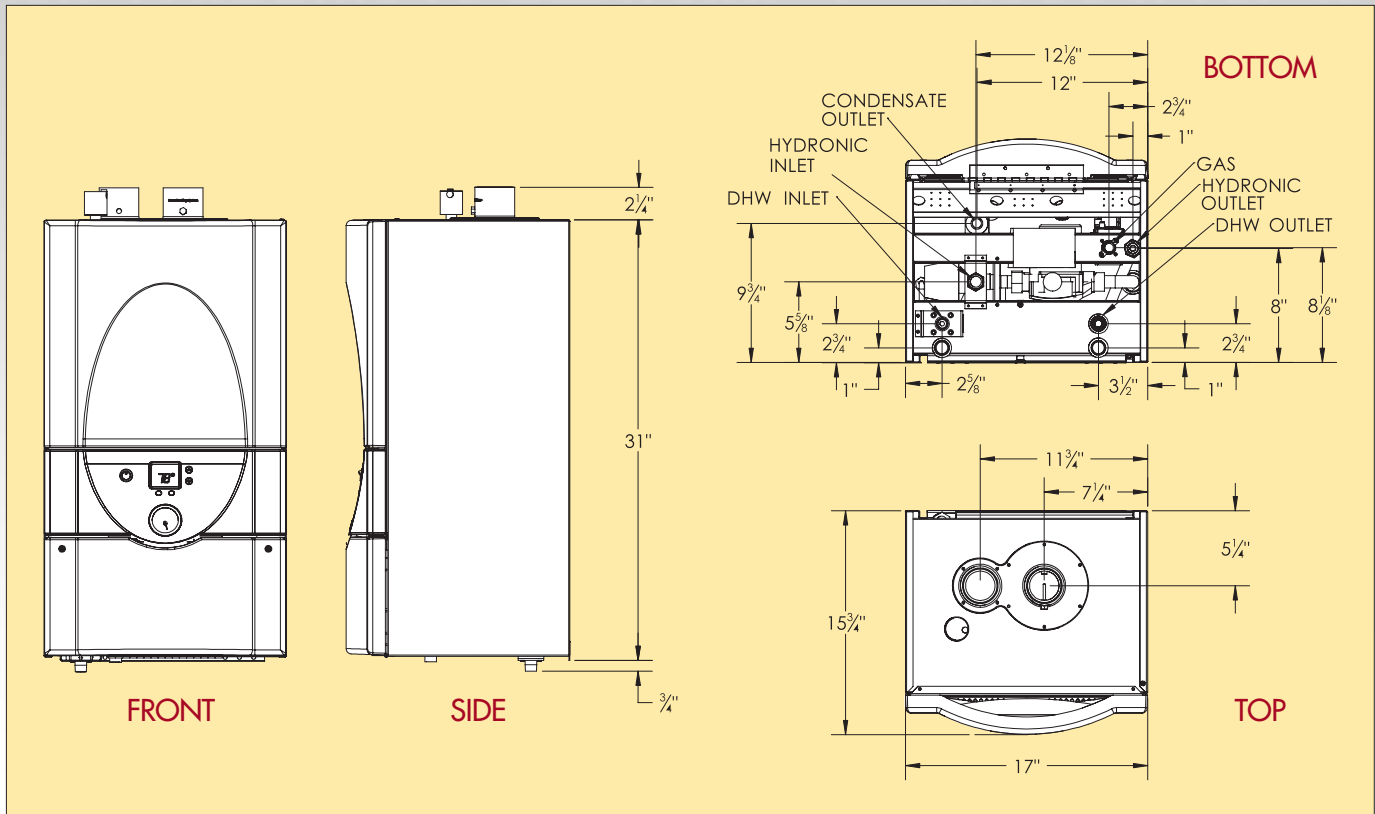

LAARS® MASCOT® II SPECIFICATIONS

DESCRIPTION	UNITS	MASCOT II - 125	
Fuel		Natural Gas / LP Gas	
Input, max fire	BTU/hr (kW)	125,000	(36.6)
Output, max fire	BTU/hr (kW)	121,250	(35.5)
DHW Max Outlet Water Temp	°F (°C)	180	(60)
DHW Max Flow Rate (dt@60°F)	gpm (l/m)	4.0	(15.1)
Flow Rate, min	gpm (l/m)	0.5	(1.9)
Pressure Relief Setting	psi (kPa)	30	(207)
Gas Connection	in (cm)	1/2	(1.3)
Supply Flow Connection		3/4	(1.9)
Return Flow Connection	in (cm)	3/4	(1.9)
Burner and Heat Exchanger Material	— —	Stainless Steel	
Weight	lbs (kg)	100	(45.4)
Service Clearances			
Top and Bottom	in (cm)	24	(61)
Sides	in (cm)	6	(15.2)
Air Vents			
Two Pipe Flue Terminal	in (cm)	2	(5.1)
Concentric	in (cm)	3 / 5	(7.6 / 12.7)
Electrical Supply			
Voltage	V	120	
Frequency	HZ	60	

THE MASCOT® II

- Operates quietly, smoothly and reliably
- Energy Star rated, 95% Efficient (AFUE)
- Low emissions, 10ppm NOx
- Zero installation clearance, fits almost anywhere
- Easy to install, setup and service
- 2 year parts, 10 year heat exchanger warranty



100% CUSTOMER SATISFACTION GUARANTEE

If your Mascot II requires more than two warranty service repairs during the first year of operation, we will replace the boiler at no charge!

This program rivals any in the industry. All you have to do is have the boiler installed and started up per the installation & operations manual and register with Laars via a 10-Point installation checklist. It's that simple, Laars is engineered to be the best.

Ask your local Laars representative for details.

MASCOT® II APPLICATIONS

- Perfect for radiant floor heating applications, with no restriction on low return water temperatures
- Approved for closet and alcove installations – perfect for condominiums and town homes
- Great for saving space by combining heating and domestic hot water in one small appliance



**American design, with clean
appliance look and feel**

LAARS®
Heating Systems Company
A subsidiary of **BRADFORD WHITE®** Corporation



View our entire product line at www.Laars.com



LAARS[®] 
Heating Systems Company
 A subsidiary of **BRADFORD WHITE**[®] Corporation

800.900.9276 • Fax 800.559.1583 (Customer Service, Service Advisors)
 20 Industrial Way, Rochester, NH 03867 • 603.335.6300 • Fax 603.335.3355 (Applications Engineering)
 1869 Sismet Road, Mississauga, Ontario, Canada L4W 1W8 • 905.238.0100 • Fax 905.366.0130

www.Laars.com